

BUZZRACK

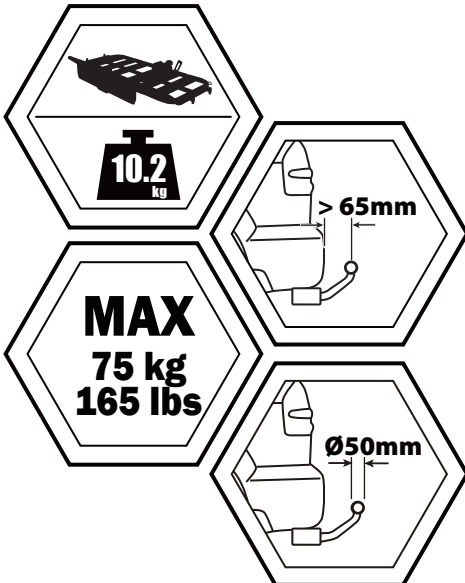
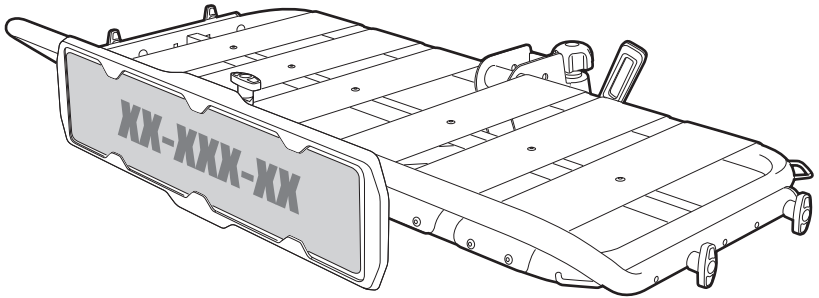

BUZZPRO P10S

PART LIST

x1

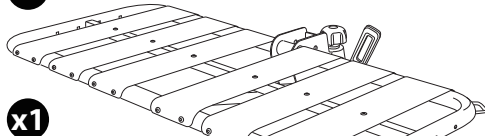

x1



x1

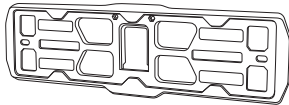

x4

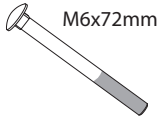

x5



x1

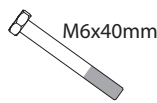

x1



x4

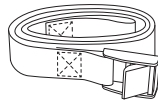

x4

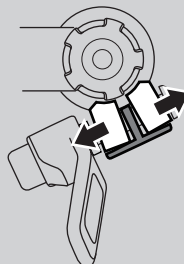
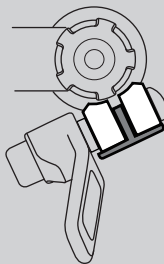
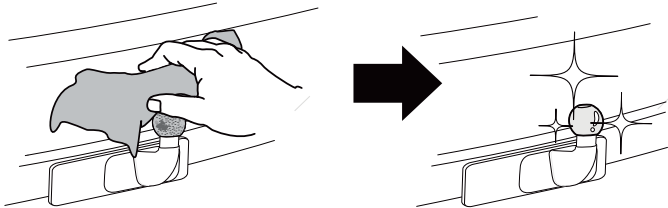
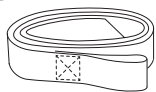

1

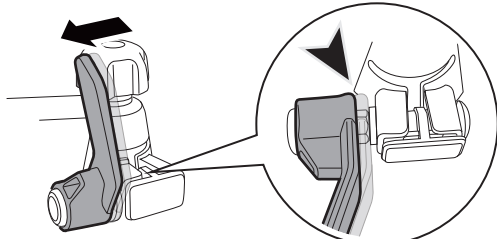

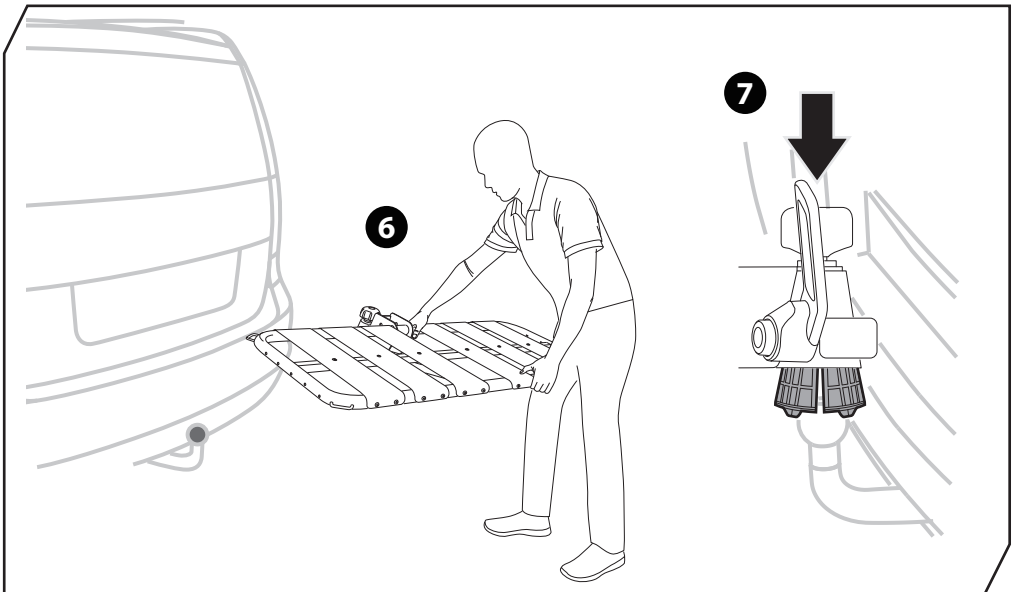
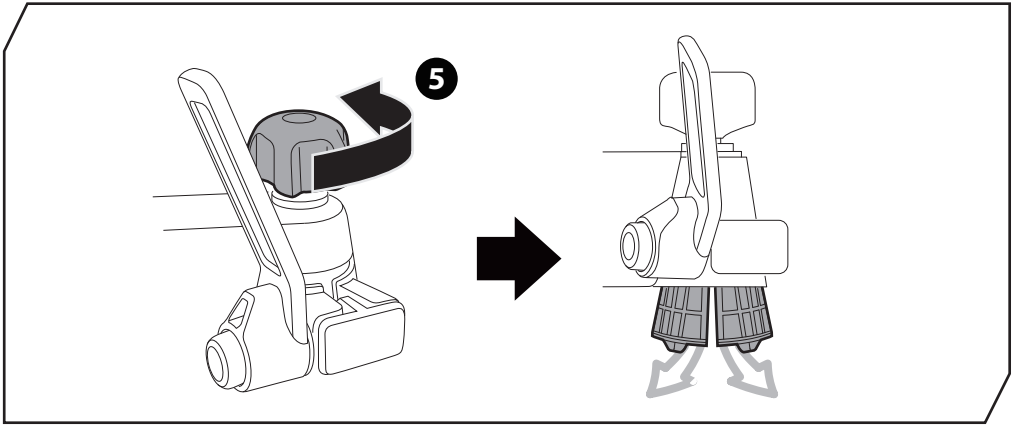
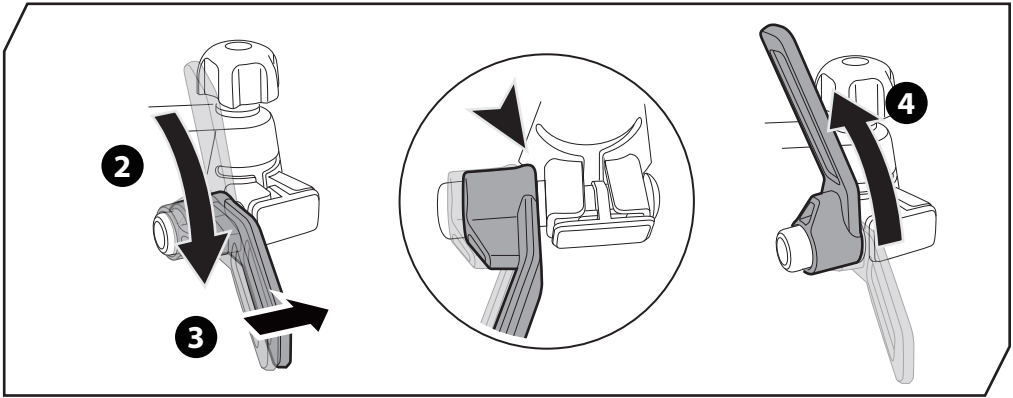

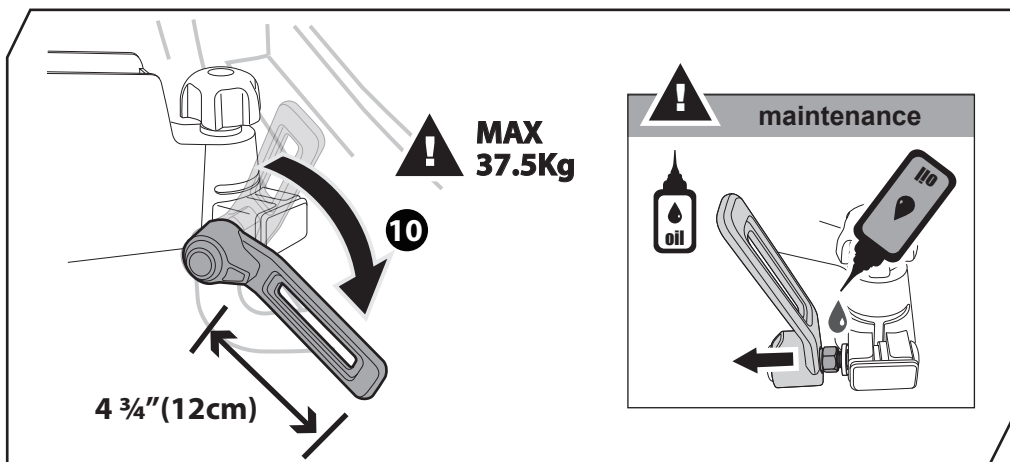
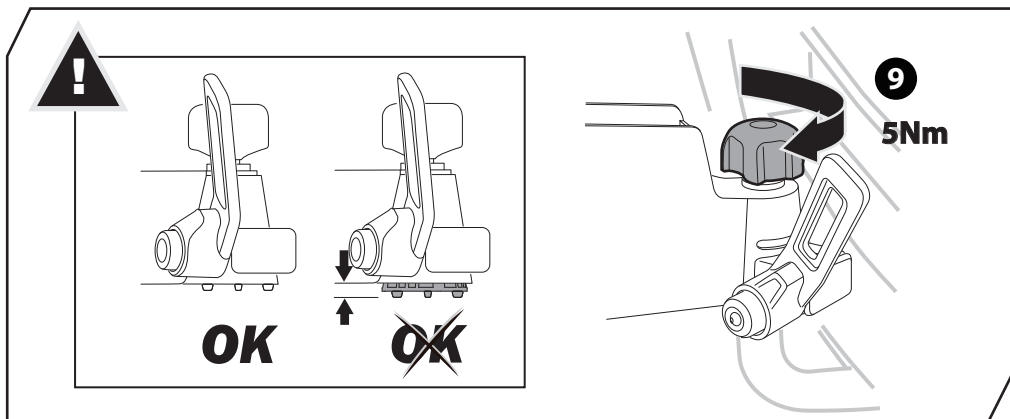
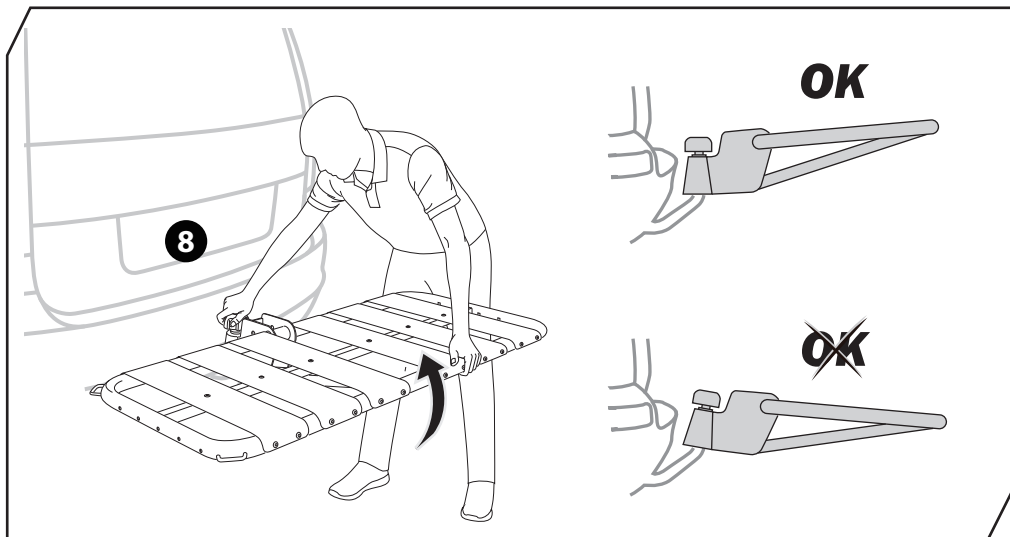

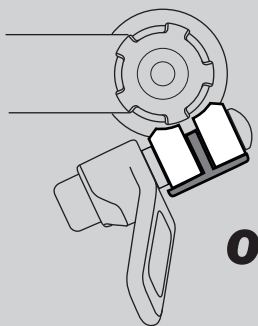
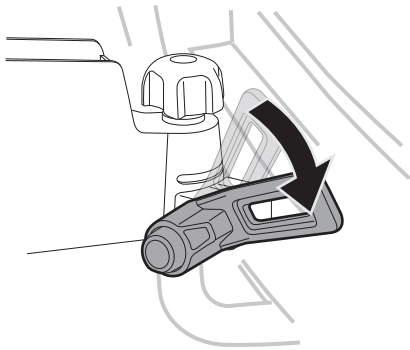
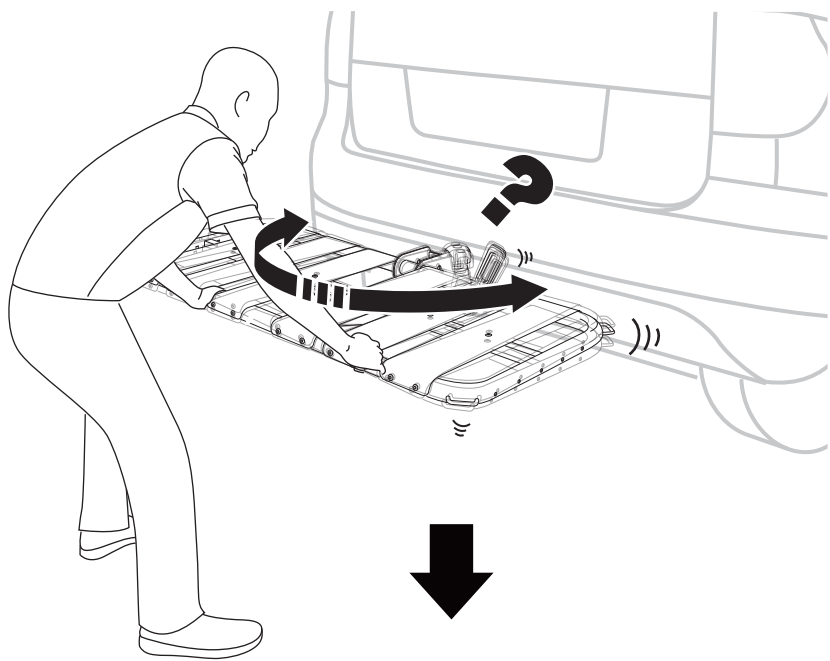

OK

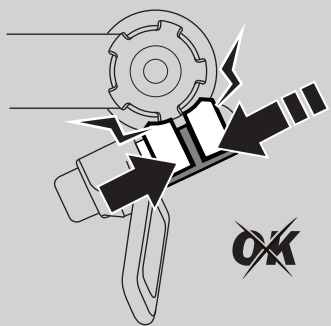

~~OK~~



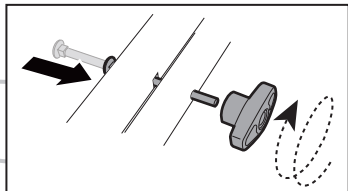
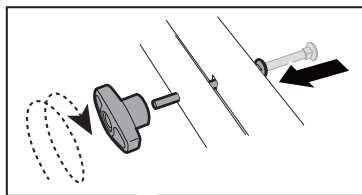

1

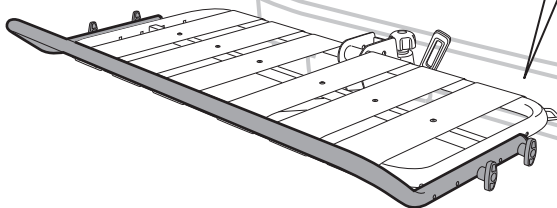

MAX 63cm

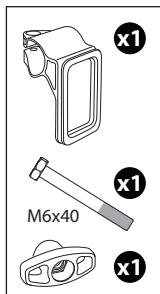
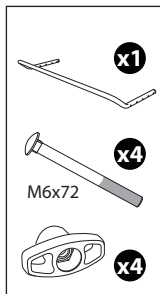
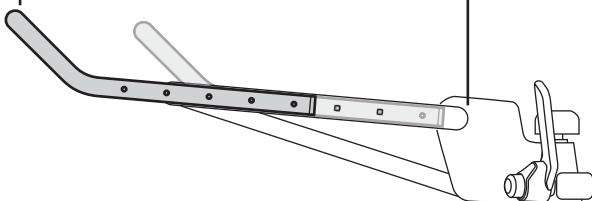

2

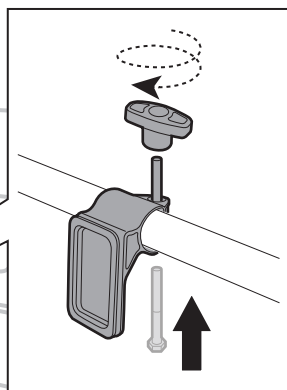
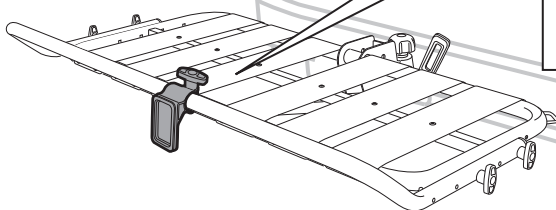

* This plate is not included.

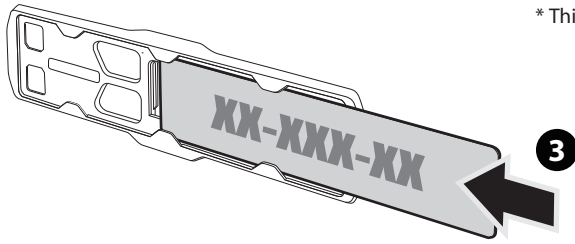

Denmark only 504x120mm

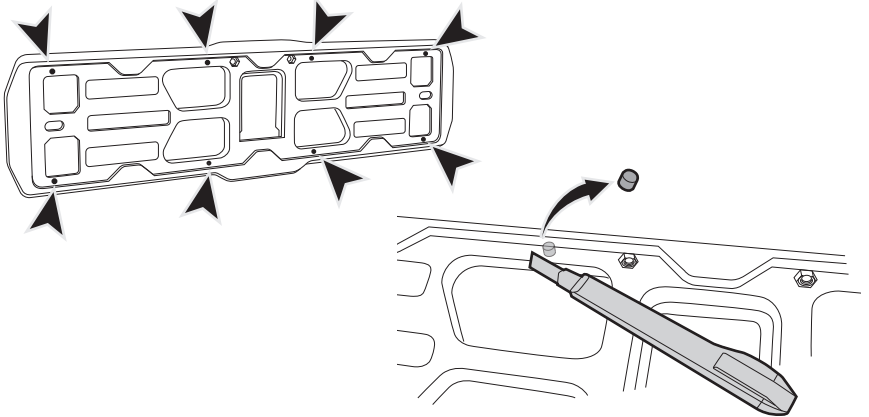

* This tool is not included.

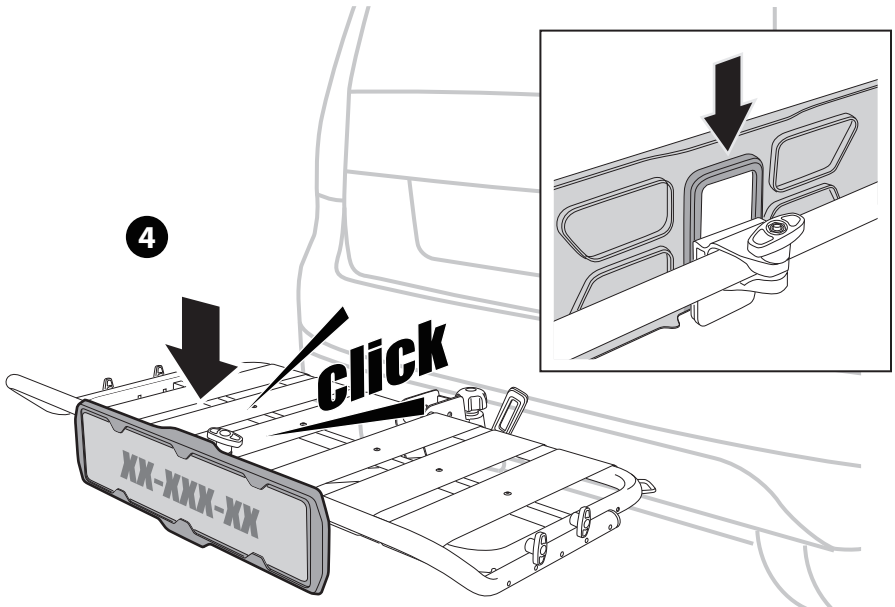

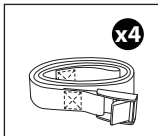

5 x4

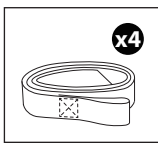
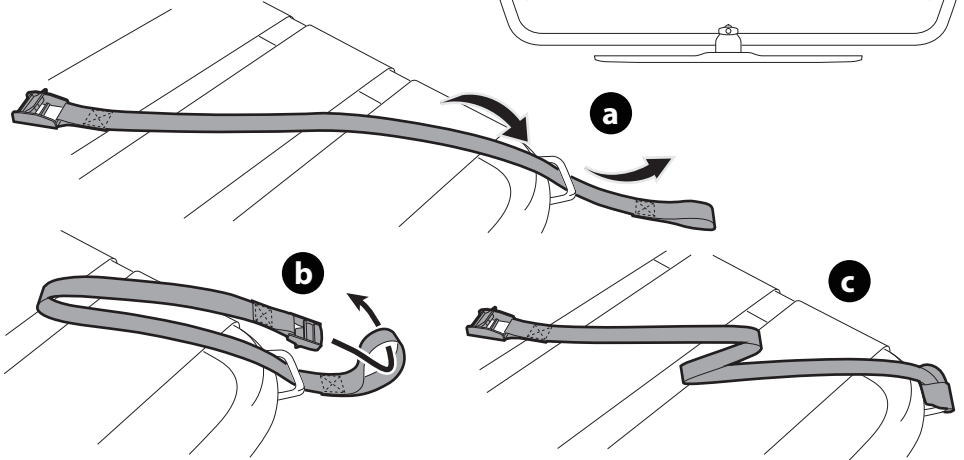
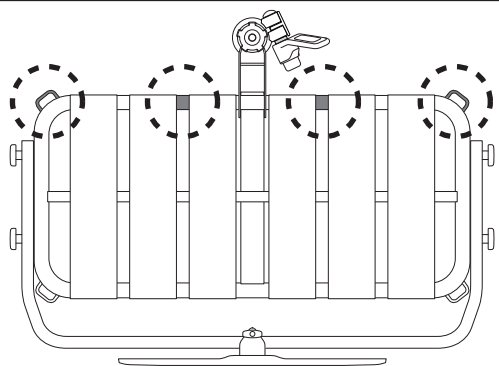

6 x4

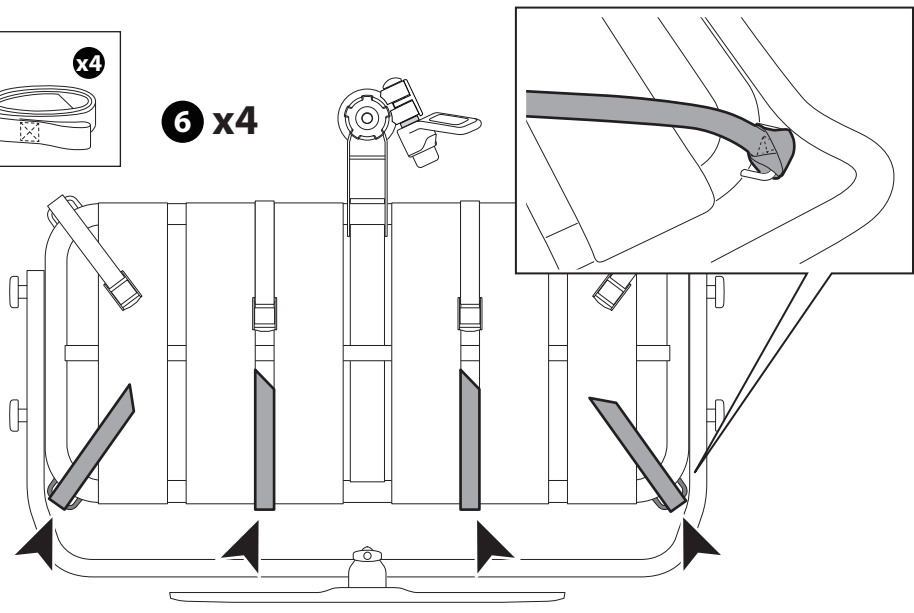

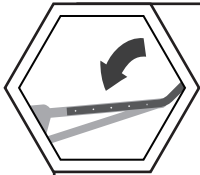

1

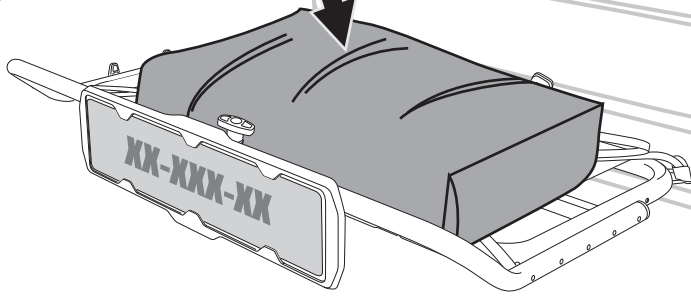

2

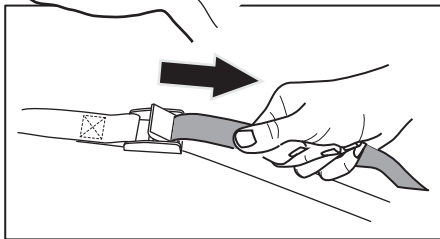
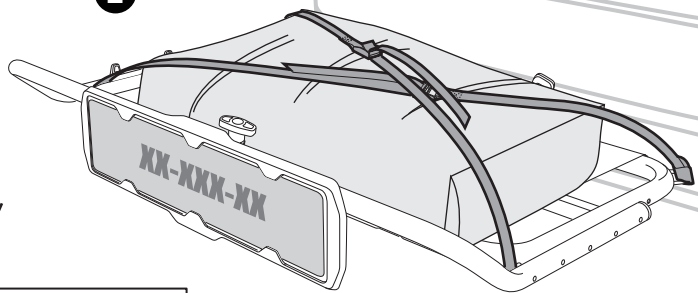

3

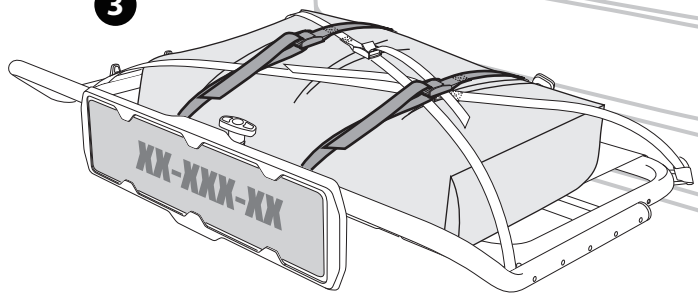

**MAX
75KG**

MAX 75 kg

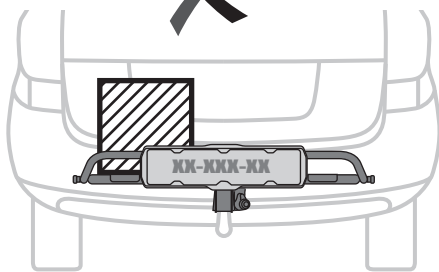
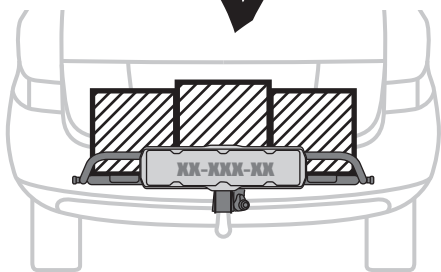
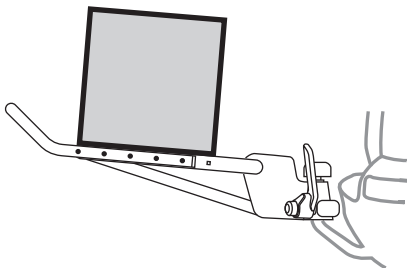
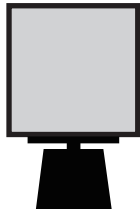

ACCESSORIES (NOT INCLUDED)

LIGHT KIT

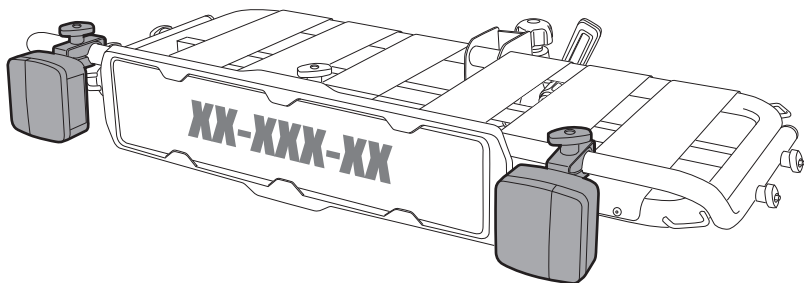
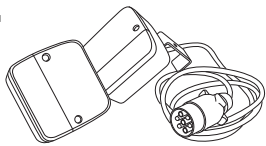



WARNINGS

EN

GENERAL REMARKS

1. Please read and observe the instructions carefully before you use the product, and keep them in a safe place for future use. Check the part list after opening the package. Make sure that all the parts are fully assembled according to the instruction before fitting it on your car.
2. The user is responsible for assembly and installation of this product, and the manufacturer disclaims any liability due to improper fitting or use of the product.
3. Failure to properly install the product and/or heavy loading may cause damage to the vehicle and/or the objects, and may result in personal injury.
4. Do not use this product for purposes other than those for which it is designed. Do not modify any components of the product. Remove the carrier if not in use.
5. Do not use the carrier to carry more weight than recommended in the chart in page one of the manual. Total weight limitation (platform + load) depends on the tow ball capacity "S" given by manufacturer.
6. Fits 50mm ISO tow balls. Always check the weight limitation of your towing system and never overload it.
7. Do not install the product on trailers, campers, or RVs.

SAFE AND PROPER USE

1. Please make sure you clean the surface of the towball completely before installing the rack.
2. Always use safety straps provided to secure the load.
3. Always check that load is evenly distributed on the platform.
4. The user is responsible for periodically verifying that all hardware, straps, knobs, hubs are securely tightened for safety purposes.
5. You might have to use more webbings to secure your loading.
6. Do not open the gate with the platform installed on the carrier.
7. The locks used on this rack are theft deterrent.
8. Before leaving and at every stop, please check that all the parts and cargo are firmly tightened.

ROAD SAFETY

1. If the carrier obstructs the vehicle's tail lights and license plate, you must use an additional signal board.
2. The rack increases the vehicle's length and weight. Be aware of this when passing through narrow or low clearance spaces and when reversing. Any loads exceeding the indicated dimensions must nevertheless respect existing regulations and be properly strapped down.
3. The load on the rack will affect driving. Do not exceed the speed limit, and do not drive faster than 120 km/h (75 mph).
4. Drive slowly over speed bumps. Respect the speed limit, and adapt your speed to the condition of the road.
5. Off-road driving is not recommended and could result in damage to your vehicle, hitch receiver, platform, or your load.
6. If you hit a bump or a hole in the road, stop your vehicle and inspect the load and the carrier. If you notice anything wrong, remove the load and do not use the carrier.
7. Make sure there is a safe distance between the load and the ground, especially when entering a driveway.

MAINTAINING YOUR BICYCLE RACK

1. Periodically inspect the product for signs of wear, corrosion, and fatigue.
2. Do not use the carrier with defective parts, contact the dealer to replace them before using it again.
3. Remove the product before entering an automatic car wash.
4. To keep your product in the best condition, it is recommended to remove the product from the car when not in use. Please be advised that this product is not designed to resist extreme weather conditions, especially seacoast air.
5. Lubricate the bolts in order to avoid corrosion.

AVERTISSEMENTS

FR

GENERALITES

1. Lire attentivement les instructions et les conserver pour une utilisation ultérieure. Vérifier la liste des pièces à l'ouverture de la boîte. S'assurer que le produit est assemblé selon les instructions avant de le monter sur le véhicule.
2. L'utilisateur est entièrement responsable de l'assemblage, de l'installation et de l'utilisation du produit. Le fabricant et le distributeur ne pourront être tenus responsables de réclamations suite à une utilisation inadéquate du produit.
3. Une mauvaise installation du produit ou un chargement trop lourd peut entraîner des dommages matériels au véhicule ainsi qu'au produit ou au chargement et dans le pire cas des dommages corporels.
4. Ne pas utiliser le produit à d'autres fins que celles pour lesquelles il a été conçu. Ne pas modifier de composants du produit. Retirer le produit lorsque vous ne l'utilisez pas.
5. Ne pas transporter plus de charge que recommandé dans notre tableau des préconisations en première page de la notice. La charge totale (plateforme + chargement) ne doit pas dépasser la charge maximale "S" admise par l'attelage.
6. Ce produit est conçu pour être monté sur une boule d'attelage ISO de 50mm. Toujours vérifier la limitation de poids sur l'attelage et ne jamais la dépasser.
7. Ne pas installer ce produit sur une remorque, une auto-caravane (camping-car) ou une maison mobile.

UTILISATION DU PRODUIT

1. Nettoyer et dégraisser la boule d'attelage avant d'installer le produit
2. Toujours utiliser les sangles de sécurité fournies pour attacher le chargement.
3. Toujours s'assurer que la charge est correctement répartie sur la plateforme.
4. L'utilisateur a la responsabilité de vérifier périodiquement que tous les éléments de serrage ou de montage sont bien serrés pour une sécurité optimale.
5. Il est possible que vous soyez obligés d'utiliser des sangles supplémentaires pour sécuriser votre chargement.
6. Ne pas ouvrir le coffre si la plateforme est installée.
7. Les serrures ont une fonction de dissuasion du vol
8. Avant le départ et à chaque arrêt, s'assurer que tout les composants ainsi que le chargement sont fixés solidement.

SECURITE ROUTIERE

1. Si la plateforme ou son chargement cachent les feux arrière ou la plaque d'immatriculation, vous devez utiliser un système secondaire de signalisation.
2. La plateforme augmente la longueur et le poids du véhicule. Attention en cas de passage étroit et délicat ou en cas de marche arrière. Les charges débordantes du dispositif de portage doivent remplir les prescriptions de la réglementation en vigueur et être convenablement sanglées.
3. Le chargement modifie les conditions de conduite et de manoeuvrabilité. Toujours respecter les limites de vitesse sans jamais dépasser 120 km/h (75 mph) si la vitesse limite y est supérieure.
4. Conduire lentement au passage des ralentisseurs. Adapter la conduite aux conditions de la route.
5. La conduite hors route n'est pas recommandée: cela pourrait endommager le véhicule, l'attelage, la plateforme et son chargement.
6. Si, par accident, vous passez sur une bosse ou un trou, arrêter le véhicule et vérifier la plateforme et son chargement. Si vous remarquez quelque chose d'anormal sur le produit, retirer le chargement et le produit et demander conseil à votre magasin.
7. S'assurer que la distance entre le chargement et le sol est suffisante pour éviter tout contact surtout en rentrant dans un garage ou un stationnement.

MAINTENANCE DU PRODUIT

1. Examiner le produit régulièrement afin de détecter tout signe d'usure, de corrosion ou de fatigue.
2. Ne pas utiliser le produit si vous constatez que des pièces sont endommagées. Communiquer avec le revendeur.
3. Retirer le produit dans les lave-autos automatiques.
4. Il est recommandé de ne pas laisser le produit sur le véhicule quand il n'est pas utilisé. Ce produit n'est pas conçu pour résister à des environnements extrêmes, comme par exemple l'air salin.
5. Lubrifier régulièrement les vis et boulons pour éviter toute corrosion.

BUZZRACK

www.buzzrack.com

Contact us at service@buzzrack.com if you have any questions.