

TEMPTECH

# ICE MAKER

## INSTRUCTION MANUAL

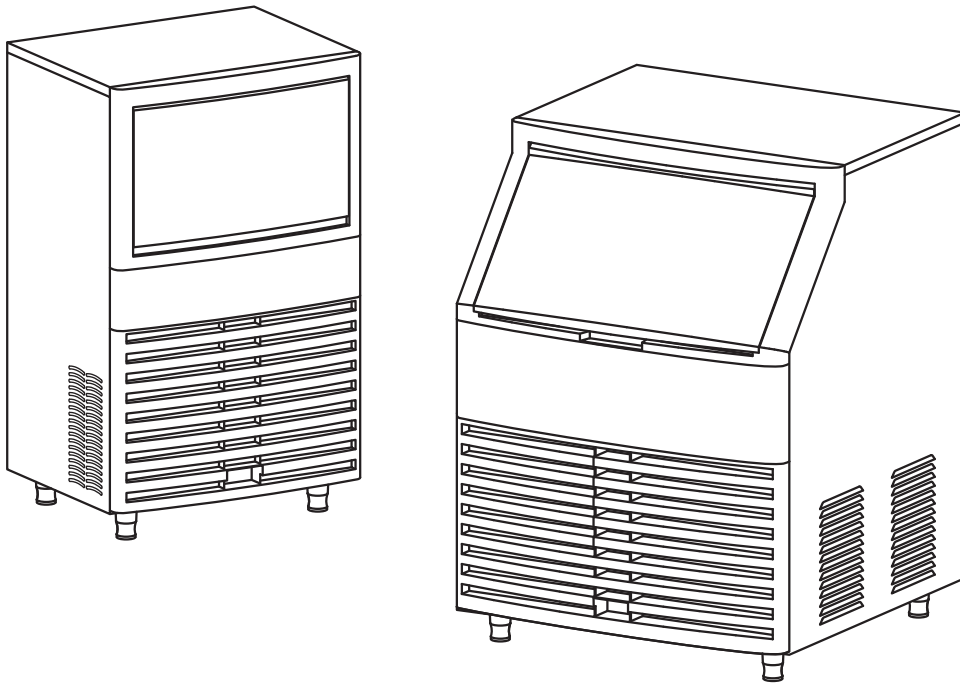

ISO 9001-2008



## **Catalog**

1 Important Safety Information.....	2
2 Ice Maker Structure .....	3
3 Accessory Installation Before Operating .....	5
3.1 Foot Installation .....	5
3.2 Installation of Water Supply.....	5
3.3 All-in-one Machine Install Instruction.....	6
3.4 Split Machine Install Instruction.....	7
4 How To Use The Control Panel .....	8
4.1 Control Panel .....	8
4.2 Power ON/OFF Control.....	8
4.3 Delay Mode .....	8
4.4 Freeze Mode .....	9
4.5 Harvest Mode .....	9
4.6 Bin Full Mode.....	9
4.7 Clean Mode .....	10
5 Fault Shows in LCD Screen.....	10
5.1 Freeze overtime .....	10
5.2 Harvest overtime .....	11
5.3 Ice flip fault.....	11
5.4 Water shortage .....	11
5.5 Condenser sensor fault.....	12
5.6 High pressure .....	12
5.7 High temperature .....	12
6 Ice-making Process .....	13
6.1 Cleaning.....	13
6.2 Ice Making process .....	13
6.3 Harvesting.....	13
7 Ice Thickness Adjustment .....	14
8 Notices and Maintenance .....	15
9 Trouble Shooting Guides.....	16
10 Before Calling For Service .....	17

Before using your Ice Makers, please carefully read this instruction manual in order to maximize its performance. Store all documentation for subsequent use or for other owners.

- Please removed all packaging, stickers and films from the products surface and clean the product's surfaces with a damp cloth and mild detergent before using for the first time.
- Let the appliance stand upright for approximately **24** hours before connecting it to the power source, which helps to reduce the possibility of a cooling-system malfunction from handling during transportation.
- The front, back, left and right side of the ice maker required at least **15cm** of space to facilitate cooling.

## 1 Important Safety Information

The Ice Makers contains a refrigerant gas and insulating gas (cyclopentane), with high compatibility with the environment, that are, however, inflammable.

We recommend that you follow the following regulations so as to avoid situations dangerous to you:

- Before performing any operation, unplug the power cord from the power socket.
- Do not install the appliance in humid, oily or dusty places.
- Do not install the appliance near heaters or inflammable materials.
- Do not use extension cords or adapters.
- Do not excessively pull or fold the power cord or touch the plug with wet hands.
- Do not damage the plug and/or the power cord; this could cause electrical shocks or fires.
- It is recommended to keep the plug clean, any excessive dust residues on the plug can be the cause fire.
- Do not damage the plug and/or the power cord; this could cause electrical shocks or fires.
- The outlet must be equipped with a ground wire, and be used correctly.
- Please remove the plug when stop using the ice makers.
- If the supply cord is damaged, it must be replaced by the manufacturer, its service agent or similarly qualified persons in order to avoid a hazard.
- **WARNING:** Do not damage the refrigerant circuit.
- **WARNING:** Keep ventilation openings, in the appliance enclosure or in the built-in structure, clear of obstruction.

## 2 Ice Maker Structure

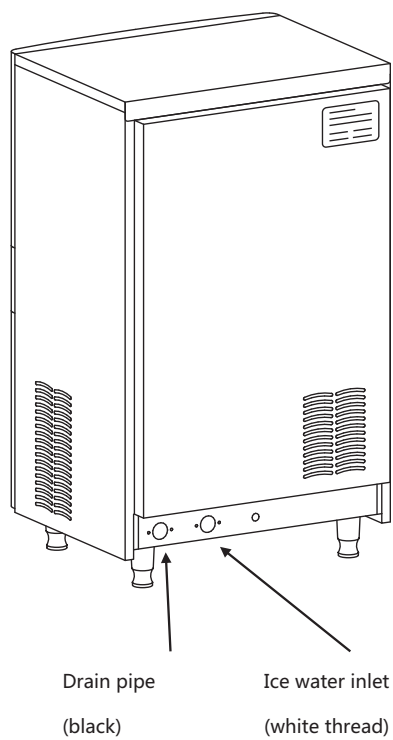
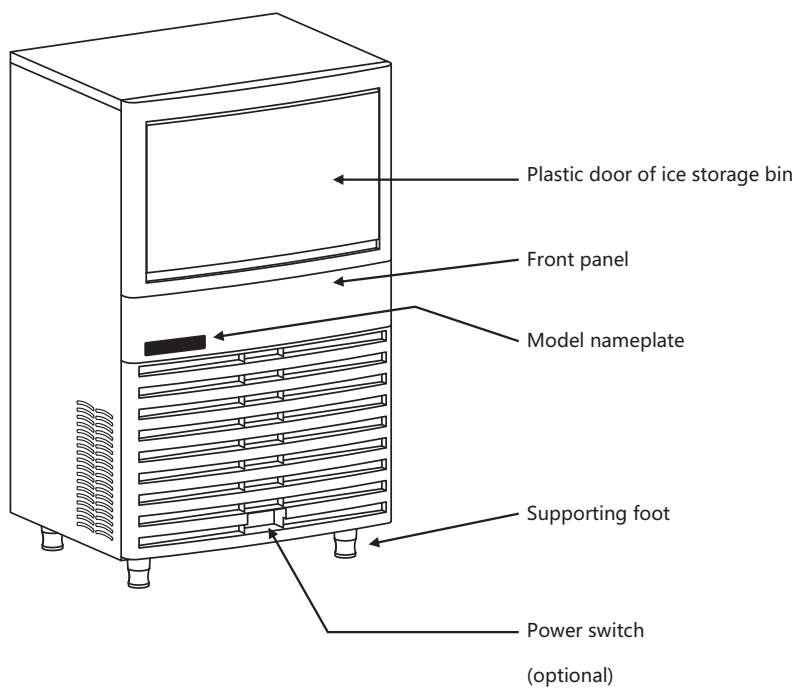

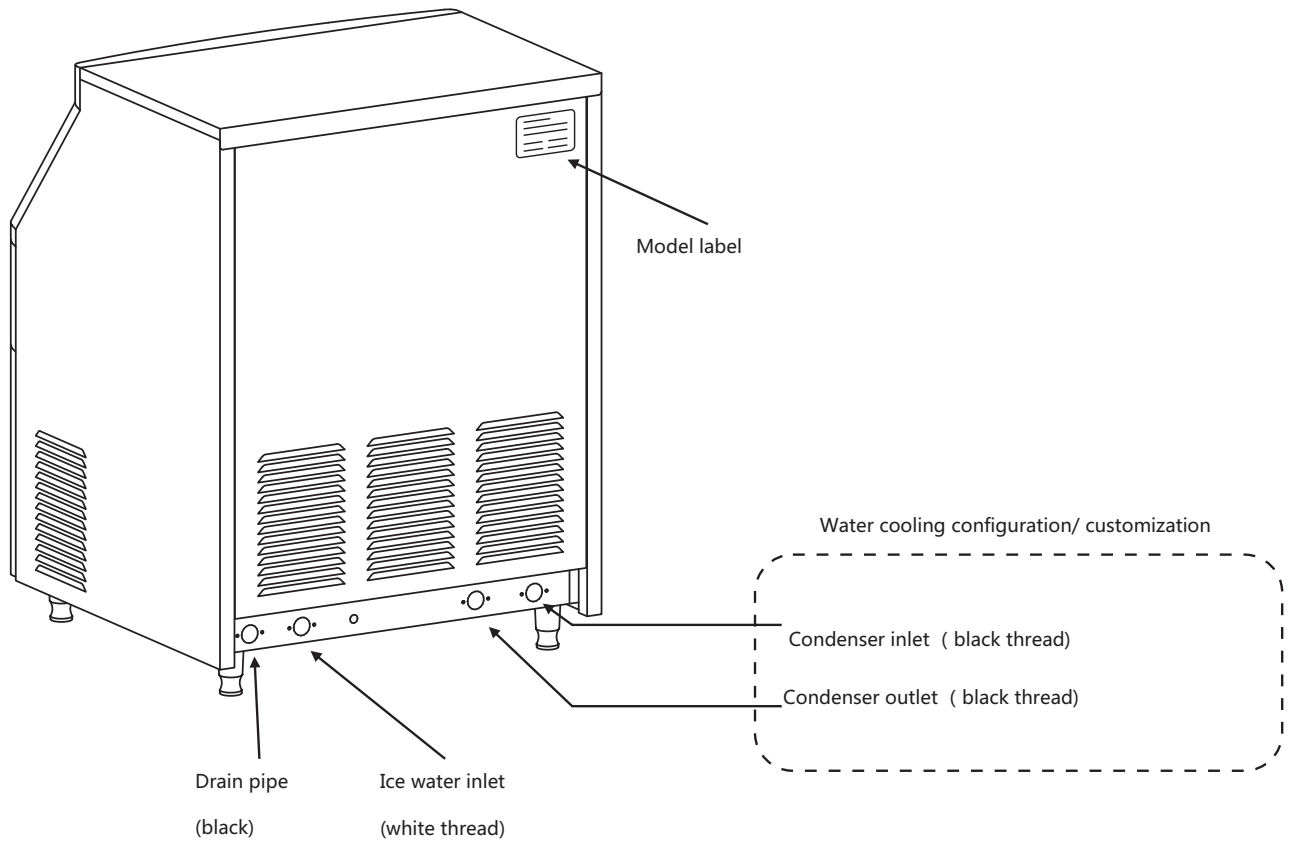

## 3 Accessory Installation Before Operating

### 3.1 Foot Installation

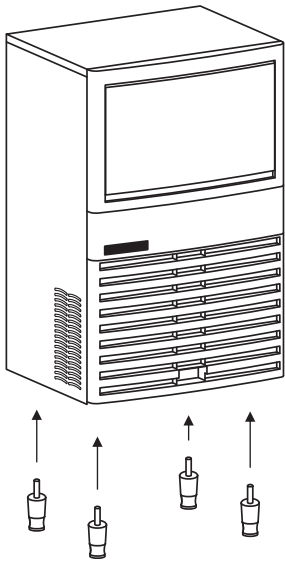

1. Screw the feet into the bottom of the ice maker.
2. Tighten each foot, to avoid bending.
3. Adjust the height of the feet to make sure the ice maker is upright and horizontal.
4. Do not use ice maker outdoor. Ambient temperature to use the ice makers is  $10^{\circ}\text{C} \sim 38^{\circ}\text{C}$ . Water temperature is  $5^{\circ}\text{C} \sim 30^{\circ}\text{C}$ . (Note: The capacity of ice makers will be reduced if using under higher ambient and water temperature.)

### 3.2 Installation of Water Supply

1. Ice maker must be connected with filtered and drinkable water at room temperature.
2. Water pressure must be controlled between 0.3 and 2Mpa. If overpressure, user should install reducing valve to avoid the water inlet hose are squeezing.
3. The dimension of two sides of female thread for water inlet hose should be  $3/4''$  (20mm) and  $1/2''$  (15mm). There are silicone gaskets installed together with the water inlet hose, no need to use tape.
4. Before using the machine, please open the filter, take out the filter cartridge and tear off the package. Then install and tighten the filter cartridge back to the filter.
5. It is recommended to replace a brand new filter cartridge every six months.
6. There are marks on the cover of the filter for inlet and outlet direction.
7. Please connect the  $3/4''$  inlet hose (White  $3/4''$  male thread) with the machine. The  $1/2''$  connector should be connected with the water supply pipe.
8. There are two  $3/4''$  male pipe in black color on the water-cooled ice makers, please note that they are different with the water inlet.
9. Ice makers drain off water under gravity. Therefore, it's important to have enough slope and fall head to support the drainage system.

### 3.3 All-in-one Machine Install Instruction

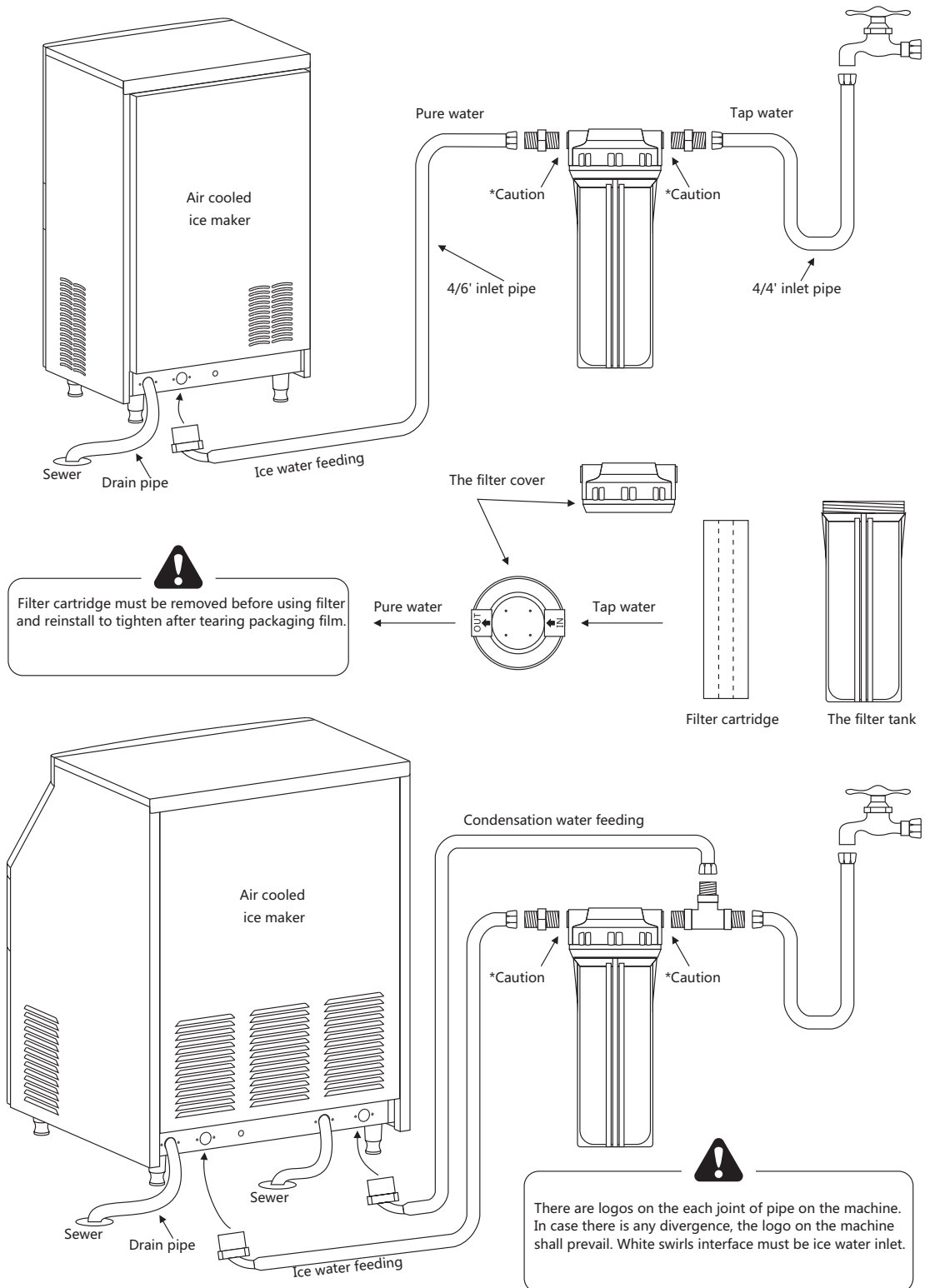

\*Caution : Mark swirls interfaces need wrapping tape.

### 3.4 Split Machine Install Instruction

1. There is one more inlet and outlet connector for water-cooled machines.
2. The drain hole is on the bottom of the machine.
3. Install the 4/6' threaded adapter on the drain hole. Then connect with 4/6' drain weep.

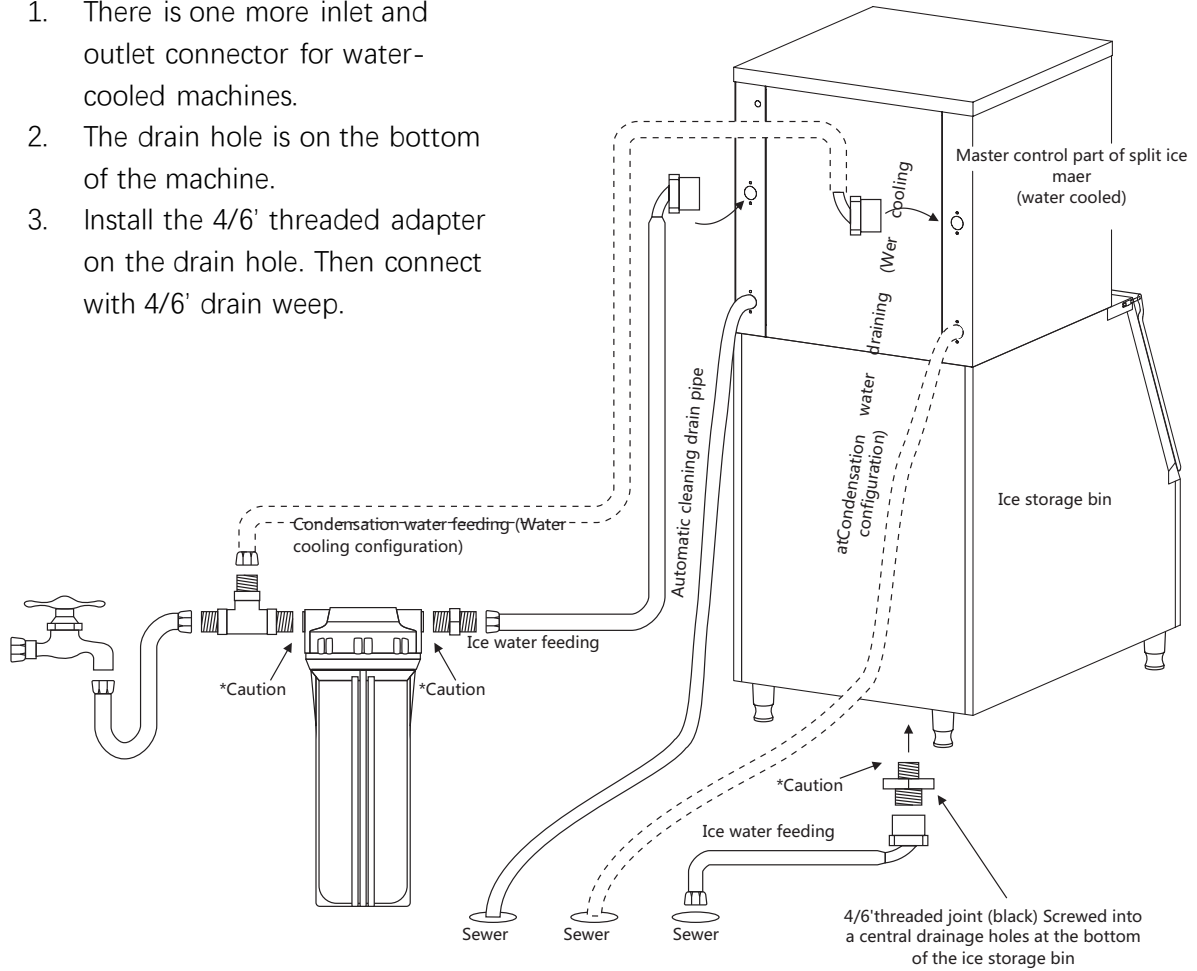

**!**

Since pressure exists in the condensation water draining pipe, water draining pipe can not be in series with other draining pipes to prevent backflow into the machine. Must be independent inserted into the sewer.

**!**

The Company complimentary single-stage filter can not meet drinking water standards, and purchase by yourself to replace.

\*Caution : Mark swirls interfaces need wrapping tape.

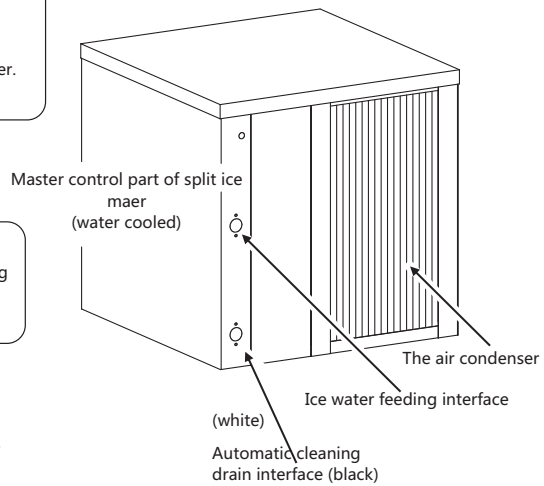



## 4 How To Use The Control Panel

### 4.1 Control Panel

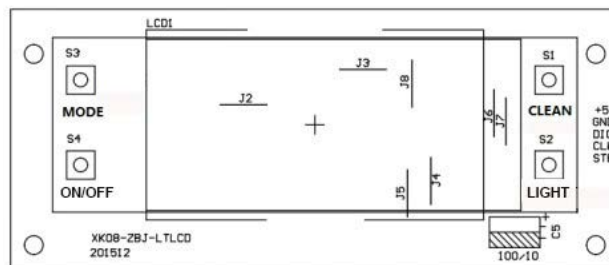

### 4.2 Power ON/OFF Control

The first time you use the machine, please plug in to a power outlet and connect with a water hose, then press **ON/OFF** button to turn on the ice maker.

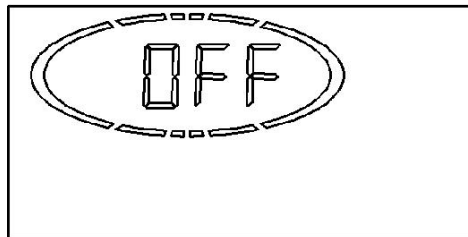

#### Notes:

- (1) When the machine is running, press **ON/OFF** button to enter standby mode.
- (2) When the machine is in standby mode, the LCD screen will show OFF. Press **ON/OFF** button to turn on the cabinet

### 4.3 Delay Mode

- 1 minutes after the machine is turned on, the machine will enter delay mode, icon for Freeze, Harvest, Bin full, Clean will be turned on automatically. The display panel will display C00.

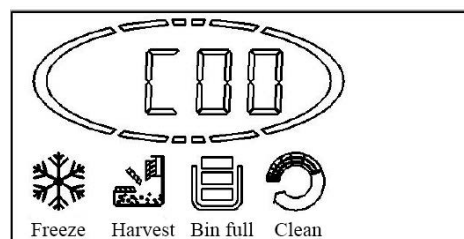

- In delay mode, press **ON/OFF** button to enter standby mode.
- In delay mode, press **MODE** button, the machine will start Freeze mode (Ice is not full)/ Harvest the ice/Bin full mode automatically.
- In delay mode, press **CLEAN** button, the machine will go into cleaning mode.

## 4.4 Freeze Mode

The first time you start the machine, it will enter Making ice mode automatically.

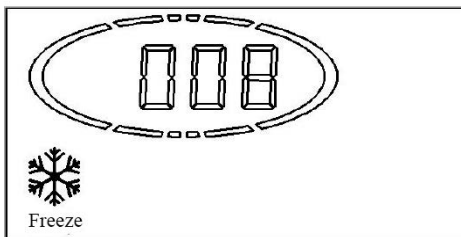

**Notes:**

- (1) When the machine is OFF, please follow step 4.2 to operate the machine.
- (2) When the machine is in delay mode, please follow step 4.3 to operate the machine.

## 4.5 Harvest Mode

Once the freeze mode is finished, the ice maker will enter harvest mode automatically. At this time, the harvest icon will be turned on, the LCD screen will display the time needed for this process.

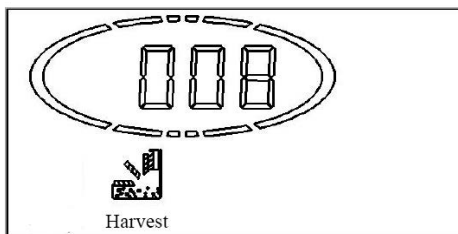

**Notes:**

- (1) The maximum time for dropping ice is **6 minutes**. If the ice haven't been dropped after 5 minutes, water pump will be turned on for 1 minute. If the ice still cannot be removed, system will enter freeze mode.
- (2) When the machine is in harvest mode, press **ON/OFF** button, you could stop dropping ice.
- (3) When the machine is in harvest mode, press **CLEAN** button, the machine will start cleaning once the ice dropping is finished.
- (4) When the machine is in harvest mode, press **MODE** button, it will enter Freeze mode (Ice is not full)/ Bin full mode.

## 4.6 Bin Full Mode

When the ice finish dropping, if the ice storage bin isn't full, the machine will start making ice. If the ice storage bin is full, the machine will stop, the Bin full icon will be turned on.

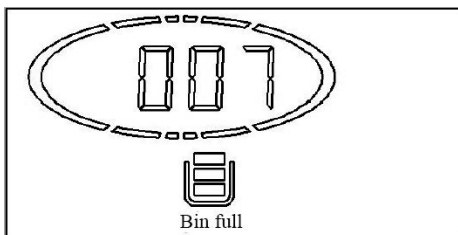

**Notes:**

- (1) In the Bin full mode, the Bin full icon will be on for 180 seconds, if you remove the ice during this period, the machine will start making ice after 180 seconds.
- (2) When the machine is in Bin full mode, it won't start a new cycle until the ice is removed.
- (3) When the machine is in Bin full mode, press **ON/OFF** button, the machine will enter standby mode.

## 4.7 Clean Mode

- The ice machine will enter Clean mode once the ice is finished dropping.

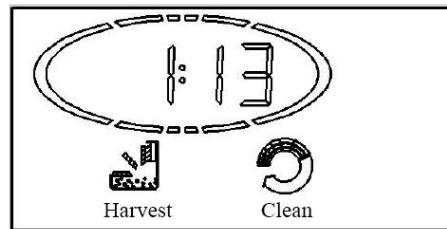

- When the machine is making ice, press **CLEAN** button, the machine will stop making ice and starting cleaning mode.
- When the machine is in delay mode, please follow step 4.3 to operate the machine.

## 5 Fault Shows in LCD Screen

### 5.1 Freeze overtime

When the ice thickness probe finds that the machine cannot produce ice in the Freeze mode, the LCD screen will show Freeze overtime and the icon for fault is on.

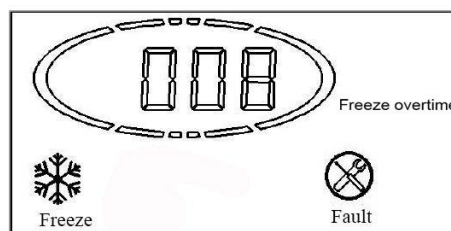

#### How to fix

- Press **ON/OFF** button to enter Delay mode, then press **MODE** button, the machine will start ice making process again.
- This problem will automatically be fixed and the machine will start making ice 30 minutes later.



If above two ways donot work, please check the water inlet, water pump, compressor, ice thickness probe.

## 5.2 Harvest overtime

If the water-retaining plate don't work three times in succession, Harvest overtime will be showed in the LCD screen and the icon for Fault will be on.

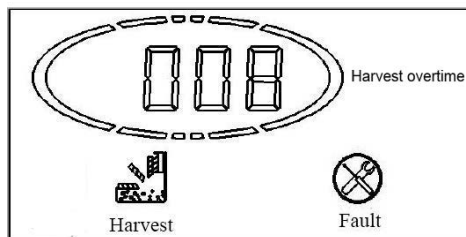

### How to fix

- Press **ON/OFF** button to enter Delay mode, then press **MODE** button, the machine will start ice making process again.
- This problem will automatically be fixed and the machine will start making ice 30 minutes later.



If above two ways donot work, please check the water inlet, water pump, compressor, water-retaining plate.

## 5.3 Ice flip fault

Water-retaining plate cannot be reset automatically, the LCD screen will show Ice flip fault and the icon for fault will be on.

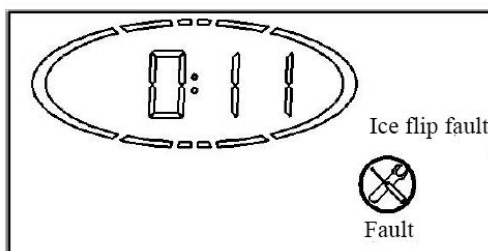

### How to fix

Check the water-retaining plate manually. The machine will enter Delay mode once the problem is fixed. Then you could follow step 4.3 to operate the machine.

## 5.4 Water shortage

If the system cannot fill the water after 5 minutes, the LCD screen will show Water shortage and the icon for fault will be on. And the machine will be turned off automatically.

The water will be added every 3 minutes and will last for 30 seconds. Once the water is full enough, the machine will enter Delay mode.

## 5.5 Condenser sensor fault

If the condenser sensor is broken, Condenser sensor will be showed in the LCD screen and the icon for Fault will be on. The ice machine won't be stopped, but the ice production will be affected. Therefore, please change a new condenser as soon as possible.

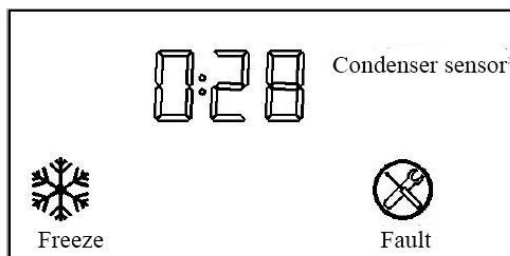

## 5.6 High pressure

When the pressure of compressor is high, High pressure will be showed in the LCD screen and the icon for Fault will be on.

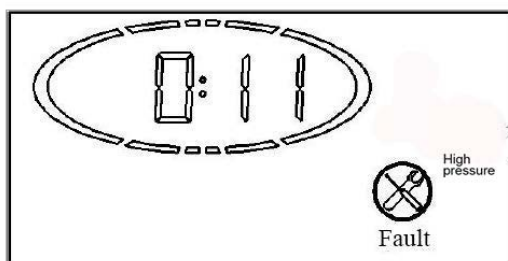

### How to fix

- The machine will automatically start 1 hour later.
- Please check the compressor, condenser fan.



Warning: When the machine is high pressure, donot operate the machine manually.

## 5.7 High temperature

If the temperature of evaporator is over 70°C, the system will be shutdown. High temperature will be showed in the LCD screen and the icon for Fault will be on.

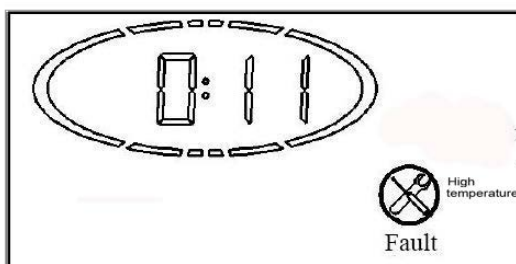

- This problem will automatically be fixed and enter Delay mode 30 minutes later.

- Press **ON/OFF** button to enter Standby mode. Then press **MODE** button if you want to run the machine again.

## 6 Ice-making Process

Once the machine is plugged in, it will start making ice automatically. There are three main steps.

### 6.1 Cleaning

Every time the machine is plugged in, it will start cleaning mode to clean the machine first. This process will take **2 minutes**.

### 6.2 Ice Making process

**45 seconds** after the cleaning mode, the pump will be turned on and start freezing.



**Notes:** The ice machine will start harvesting if the gas of ice thickness is too wide and lasted for **40 minutes**.

### 6.3 Harvesting

During the ice-making process, the ice thickness will be detected by the ice thickness probe. Once the ice is thick enough, the machine will start harvesting. This process will take **4 minutes**.

When the ice is dropping, the water-retaining plate will be flapped and reset due to the weight of the ice. Then the machine will start making ice again.

But when the ice storage bin is with too much ice to reset the water-retaining plate, the system will enter Bin full mode and stop making ice until the water-retaining plate is reset.

## 7 Ice Thickness Adjustment

The detector gap is the key to control the ice thickness. To increase the thickness of the ice, twist the screw clockwise. If you want to reduce the thickness of the ice, twist the screw counterclockwise.

Notes:

1. Every adjustment should be less than half a lap.
2. These adjustments will come into effect in next process of ice making.

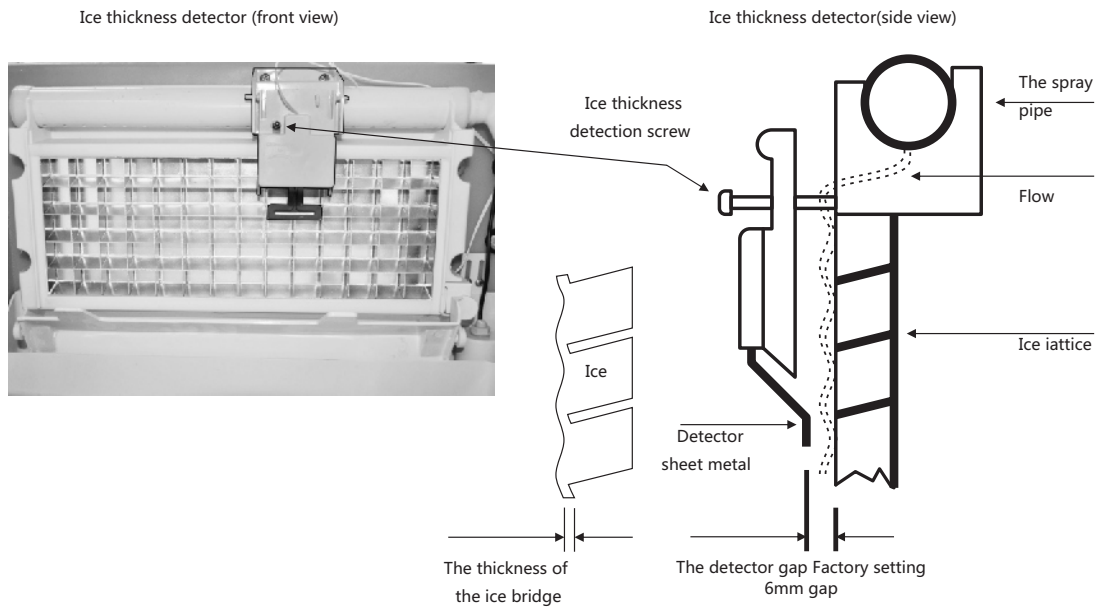

Ice thickness probe adjustment screwing each 1/4 turn and wait before they look at the effect of the de-ice accumulated no more than three rings of screwed.

## 8 Notices and Maintenance

1. It is recommended to move and transport the ice maker horizontally. The ice maker cannot be tilted exceed 45°.
2. Ice maker should use separate water supply.
3. Check the water pressure and filter regularly.
4. Do not store any debris, frozen or iced food in the ice storage bin. And keep the ice scraper clean.
5. Please open or close the door of ice storage bin gently. Do not break the door.
6. Please close the door after taking out the ice.
7. Clean the room regularly to make sure the ventilation louver of ice maker won't be blocked by the dusk.
8. It is recommended to check and change the filter cartridge every 6 months. If using advanced cartridge, it should be replaced according to its instruction.
9. The water tank and ice storage bin can be wash by water directly. But water pressure couldn't higher than 2Mpa.
10. To protect the circuit parts, do not flush above ice lattice sections and surface of the machine with water directly.
11. Condenser of air-cooled ice maker should be cleaned by a soft brush every 3 months.
12. Winter maintenance: Cut off water supply and electric, and make sure there is no water left on the tank, inlet and drain pipe.
13. If stop using the ice maker for a long period, it should be plugged in and operated for 4-6 hours every 2 months.

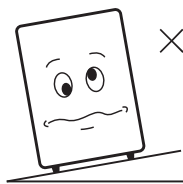

Place smoothly

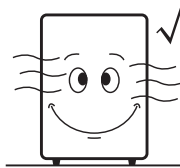

Ventilate well

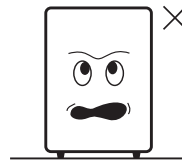

Avoid exposing to the sun and rain



Before performing cleaning and maintenance work, be sure to turn off the water and power supply, pull the plug.



If the scale in the ice maker is serious, or clogged waterways, please call telephone service. Note : on-site service is not free of charge.



The filter cartridge should be replaced periodically.



Air-cooled condenser fins with sharp edges, please use caution when cleaning.



## 9 Trouble Shooting Guides

Problem	Possible Cause	Solution
Ice maker does not start	Socket is poor contacted.	Replace a new socket
	Ice storage bin is full of ice	Take out the ice, then the machine will run automatically.
	Flap is not reset	Adjust the flap manually
Ice maker goes down after operation	Water isn't opened, or water inlet isn't connected tightly	Recheck the source of water and water inlet
	Machine isn't horizontal	Adjust the feet
	High pressure, switch is turned off	Open the front panel, clean the condenser
Capacity of ice cannot reach the standard	Do not clean the machine for more than 2 months	Open the front panel, clean the condenser
	Water temperature is too high (In summer)	/
	Environment temperature is too high	Clean up debris around the machine.
	Space of the machine is small or closed	Clean up debris around the machine.
	After failure of the inlet valve, it opens automatically	Replace the inlet valve
Transparency of the ice is poor or the ice is incomplete	Improper ice thickness probe	Reset the ice thickness probe
	Poor water quality	Install filter, replace the filter cartridge
	Ice maker tank and ice lattice are dirty.	Clean the ice maker, replace the filter cartridge
	Water inlet valve filter is dirty	Clean the inlet valve filter
	Too much water above ice lattice	Silicone tube truss pumps, throttle
	Drain valve regularly close after the failure	Replace the drain valve
Cannot harvest	The ice is too thick	Adjust the ice thickness probe
	Ice detector probe is dirty and loose	Clean up probe, check the connection
Too much noise	Place the machine improperly, the feet not on the ground	Place the ice machine smooth
	Ice maker shell contact other objects	Avoid contact with other objects
There is condensed water on the shell	The door of ice storage bin is not fully closed	Close the door of ice storage fully.
	Working in a high temperature, high-humidity environment	Normal

## 10 Before Calling For Service

If the ice machine is abnormal, please verify the following before you call.

1. Whether the water source of ice maker is normal.

Loosen the water inlet on the back of the ice machine to a certain extent. The water source is normal if water leak from the connector, otherwise no water in the water inlet.

2. Whether the ice machine is powered on.

Please check if the ON/OFF switch on the cabinet is on or not. If it's on, but machine didn't work, please ask electrical professionals to check, especially the socket.

3. Please provide model number and series number when calling for service. These information shows on the surface of the machine.